

USE AND MAINTENANCE MANUAL

CLAMP FOR APPLIANCES

ORIGINAL

INTRODUCTION

This manual contains instructions for assembly, periodic and extraordinary maintenance and troubleshooting.

The instructions in this manual supplement, and do not replace, the obligation to obey occupational safety and accident-prevention laws, which is the user company's responsibility. The user company is, likewise, required to follow all the instructions in this manual, including training its 1personnel to use and maintain the attachment.

SPECIFICATIONS AND USE OF THE ATTACHMENT

Attachment, to be hooked to a forklift truck, for handling cardboard packaging boxes. It consists of a jaw guide frame complete with hooks with ISO 2328 profile for fastening to the truck, with or without side shifting; a hydraulic power plant adequate for the needs of the specific handling, shifting of the load obtained with valves, jaw synchronisation, load tightening pressure adjusting system, tightening pressure gauge indicator, jaws equipped with oscillating panel support, panel equipped with vulcanized rubber handling runner, having shape and size suitable for the load to be handled, jaws motion driven by opposing linear actuators, load supporting grid.

USED SYMBOLS



Situation with possible risks for the operator's safety.



Procedure that must be performed.



Notes to read carefully.

INDEX

PART 1: FIXING TO THE TRUCK AND ADJUSTMENTS

1. RECOMMENDATIONS FOR USING THE EQUIPMENT	Page 2	7. CHECKS AND ADJUSTMENTS	Page 7
1.1. PROHIBITED MOVEMENTS	Page 2	7.1. CLAMPING PRESSURE	Page 7
1.2. CORRECT MOVEMENTS	Page 2	7.2. SPEED AND SYNCHRONISM	Page 7
2. FORKLIFT CHECKS	Page 3	7.3. JAWS ADJUSTMENT	Page 8
3. ATTACHMENT CONFIGURATION	Page 3	7.3. 1. ADJUSTING THE PANEL SUPPORTS	Page 8
3.1. FOR SHIPPING	Page 3	7.3. 2. PANEL SUPPORTS TILTING ADJUSTMENT	Page 8
4. ATTACHMENT DESCRIPTION	Page 4	8. DAILY CHECKS	Page 8
4.1. WITH/WITHOUT INCORPORATED SHIFTING	Page 4		
5. FIXING TO THE TRUCK	Page 4		
5.1. PREPARATION	Page 4		
5.2. FASTENING LOWER HOOKS	Page 4		
5.3. JAWS HOOKING	Page 5		
5.4. HOOK ADJUSTMENT	Page 5		
5.5. CONNECTING HOSES	Page 5		
6. HYDRAULIC POWER PLANT CONNECTION AND DIAGRAM	Page 6		
6.1. MOVEMENT CHECK	Page 6		
6.2.1. WITHOUT SHIFTING	Page 6		
6.2.2. WITH INCORPORATED SHIFTING	Page 6		

USE AND MAINTENANCE MANUAL

PART 2: MAINTENANCE

9.	REGULAR MAINTENANCE	Page 9
10.	EXTRAORDINARY MAINTENANCE	Page 10
10.1.	PANEL DISASSEMBLING	Page 10
10.2.	PANEL SUPPORT DISASSEMBLING	Page 10
10.3.	JAW DISASSEMBLING	Page 11
10.4.	SLIDE BLOCK DISASSEMBLY	Page 11
10.5.	SLIDE BLOCK REPLACEMENT	Page 12
10.6.	CYLINDER ROD FASTENING	Page 12
10.7.	CYLINDER BOX FASTENING	Page 12
10.8.	CYLINDER DISASSEMBLY	Page 12
10.8.1	GASKET REPLACEMENT	Page 12
10.8.2	GASKET ASSEMBLY	Page 12
10.9.	VALVE DISASSEMBLY	Page 13
10.10.	LOAD SUPPORTING GRID	Page 13
11.	TROUBLESHOOTING	Page 14
12.	NOISE	Page 15
13.	RECYCLING	Page 15
14.	WARRANTY	Page 15
15.	CERTIFICATE OF CONFORMITY (FACSIMILE)	Page 15

1. RECOMMENDATIONS FOR USING THE EQUIPMENT

1.1. PROHIBITED MOVEMENTS

Transporting an unstable or unbalanced load; too bulky, reducing visibility; of weight greater than the indicated capacity; moving an already deposited load using the load to be deposited; using the attachment when it presents structural deformations or operating anomalies.

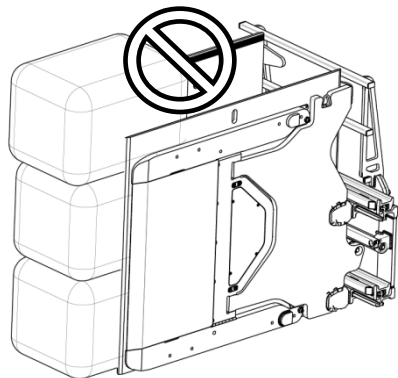

Executing movements or manoeuvres with load raised to a high level.

Proceeding at high speed on a rough surface or climbing ramps.

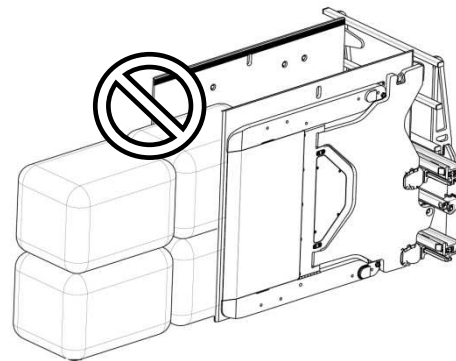

Avoid gripping boxes with just the point of the jaws. If this manoeuvre is necessary, do not tighten at full power.

Handling loads whose height can interfere with visibility during the manoeuvre.

Transporting persons or performing manoeuvres with persons in the radius of action

Parking the truck with motor running and/or load lifted on a rough surface or on climbing ramps.

1.2. CORRECT MOVEMENTS

Be careful when gripping the load to avoid damage or dangerous movements of the adjacent cardboard boxes.

The load must be stable, or tied with crossed layers or tied with straps.

When moving with the truck, keep the mast tilted (the point of the forks high), the load lifted slightly from the ground and centred, adjusting the speed based on the road surface and any obstacles or presence of persons on the rout.

USE AND MAINTENANCE MANUAL

2. FORKLIFT CHECKS

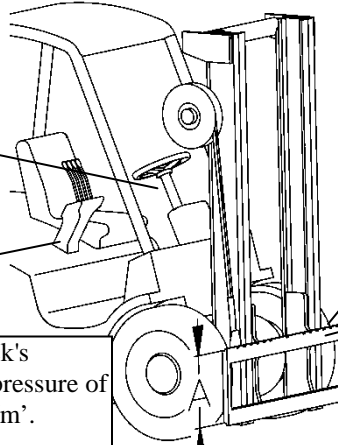

The recommended diameter for any additional power plant is 9.5 mm.

Distributor with no. 4 levers for controlling motions .

When checked at the distributor, the truck's hydraulic pump must have a maximum pressure of 25 MPa and a flow-capacity of 20 - 25 l/m'.

The fork placement notches must be in good condition and not clogged.

The fork-holder plate must be flat and without front projections.

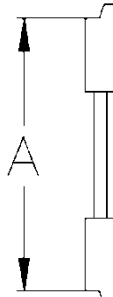

ISO 2228 Dimension "A" (mm):
 Classe I = min. 304 – max. 305
 Classe II = min. 380 - max. 381
 Classe III = min. 474.5 – max. 476
 Classe IV = min. 595,5 – max. 597

! DO NOT USE THE ATTACHMENT FOR ANY PURPOSE OR MOVEMENT OTHER THAN INDICATED.

! THE EFFECTIVE CAPACITY OF THE COMBINATION OF THE TRUCK AND THE ATTACHMENT IS THE RESPONSIBILITY OF THE MANUFACTURER OF THE TRUCK AND MAY NOT CORRESPOND TO WHAT IS SPECIFIED ON THE IDENTIFICATION PLATE. CONTACT THE MANUFACTURER OF THE TRUCK FOR ITS DEFINITIVE CAPACITY.



3. ATTACHMENT CONFIGURATION

3.1. FOR SHIPPING

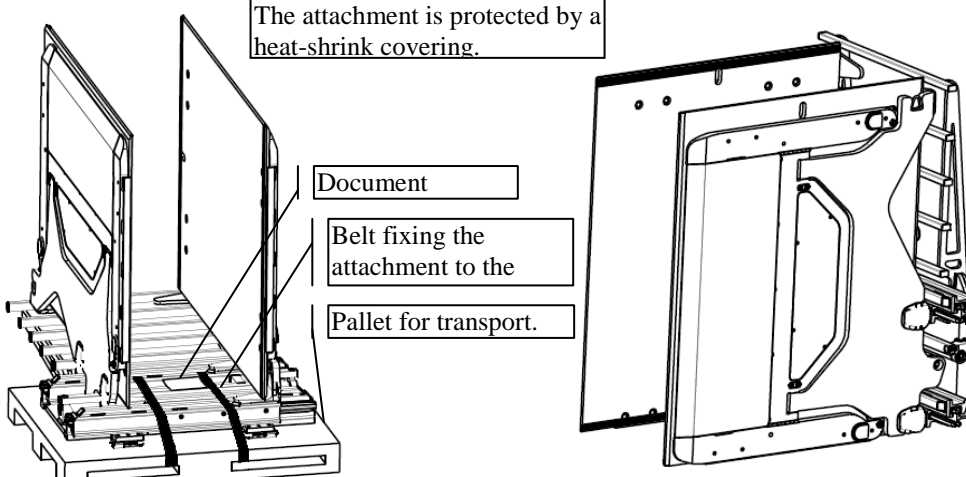

The attachment is protected by a heat-shrink covering.

Document

Belt fixing the attachment to the

Pallet for transport.

Identification plate.

CE	ANNO FABBRIC. - BAUJAHR MNFG. YEAR - ANNE FABRIC.	
TIPO - TYP TYPE - TYPE		
MATRICOLA - FABRIK NR. S. NUMBER - NR. FABRIC.		
PORTATA STRUTT. - TRAGKRAFT STR. CAPACITY - CAPACITE STRUCT.		KG
CON BARIC. A - MIT L. SP. WITH C.O.G. AT - AVEC C.D.G. A		MM
SPESSORE - VORBAUMASS THICKNESS - EPAISSEUR		MM
MASSA - EIGENGEWICHT WEIGHT - MASSE		KG
BARICENTRO - SCHWERPUNKT C.O.G. AT - C.D.G. A		MM
PRESSIONE MAX ESERCIZIO - MAX BETRIEBSDRUCK - MAX WORKING PRESSURE - PRESSION MAX SERVICE		BAR
RISPETTARE LA PORTATA COMPLESSIVA DEL CARRELLO E DELLA ATTREZZATURA - TRAGFÄHIGKEIT VON STAPLER UND ANBAUGERÄT BEACHTEN - RESPECT CAPACITY OF TRUCK AND ATTACHMENT ASSEMBLY - RESPECTER LA CAPACITÉ DE L'ENSEMBLE CHARIOT / ACCESSOIRE		

Accident-prevention

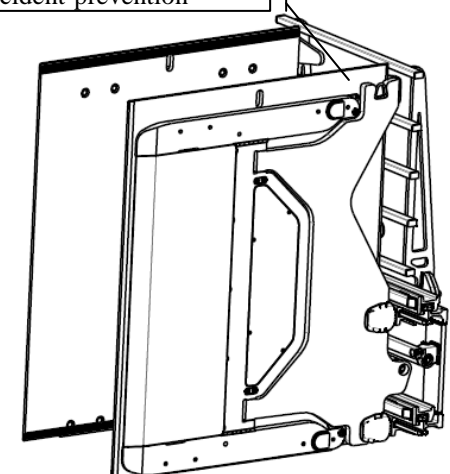

USE AND MAINTENANCE MANUAL

ATTACHMENT DESCRIPTION

4.1. WITH/WITHOUT INCORPORATED SHIFTING

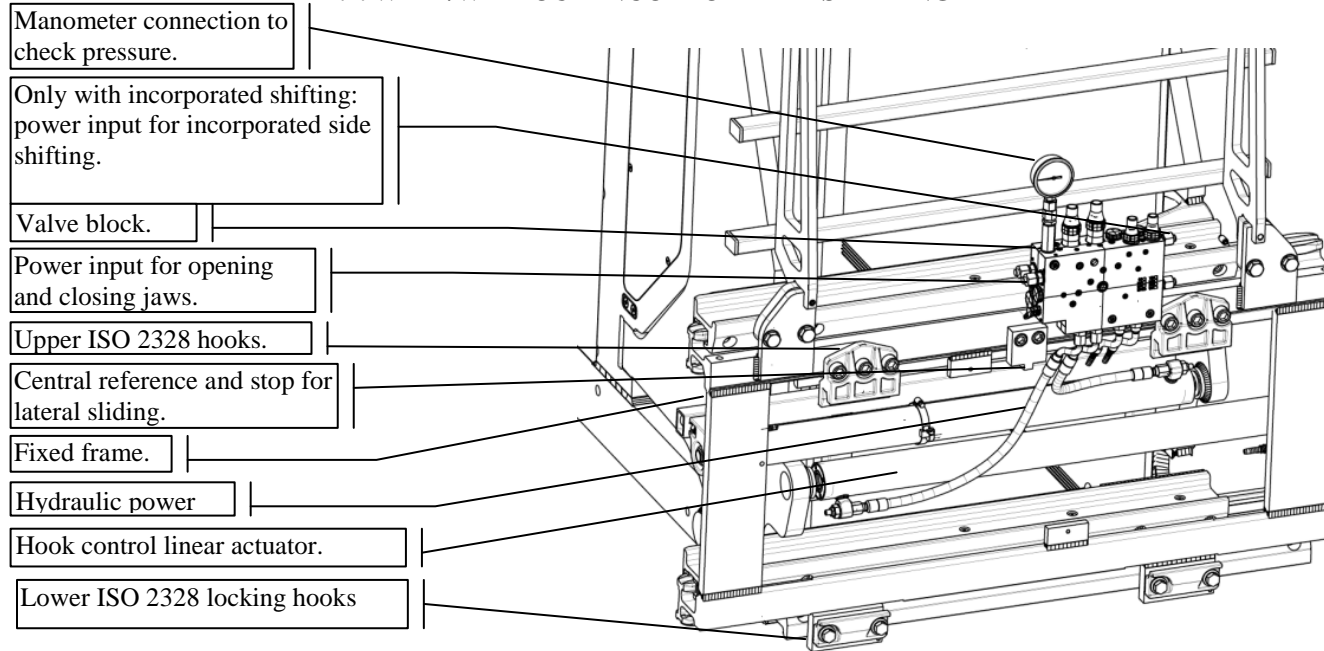

5. FIXING TO THE TRUCK

5.1. PREPARATION

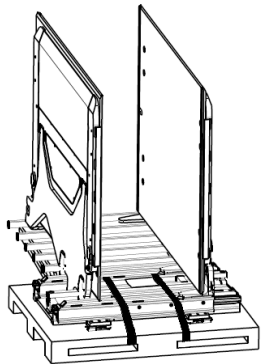

- 1) Remove the Nylon protection and the pallet fastening belts.
- 2) Fasten no. 2 eyebolts to the ends of the
- 3) Disconnect the lower jaws. ISO 3318
- 4) Use cables with UNI ISO 4479 hooks and straps to lift the attachment.

5) Hook the attachment to the truck so that the central stop engages the central notch of the fork-holder plate.

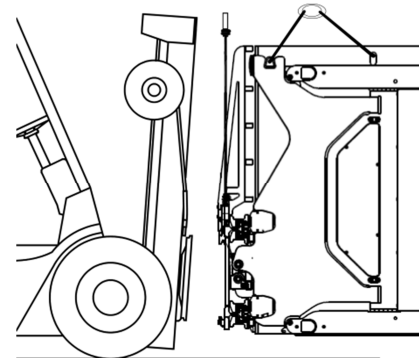

5.2. FASTENING LOWER HOOKS

Use an ISO 3318 wrench to fasten the lower jaws.

Wrench size and screw tightening.		
FEM class.	Wrenc h mm	Tightenin g N/m
2	22	120

USE AND MAINTENANCE MANUAL

5.3. JAWS HOOKING

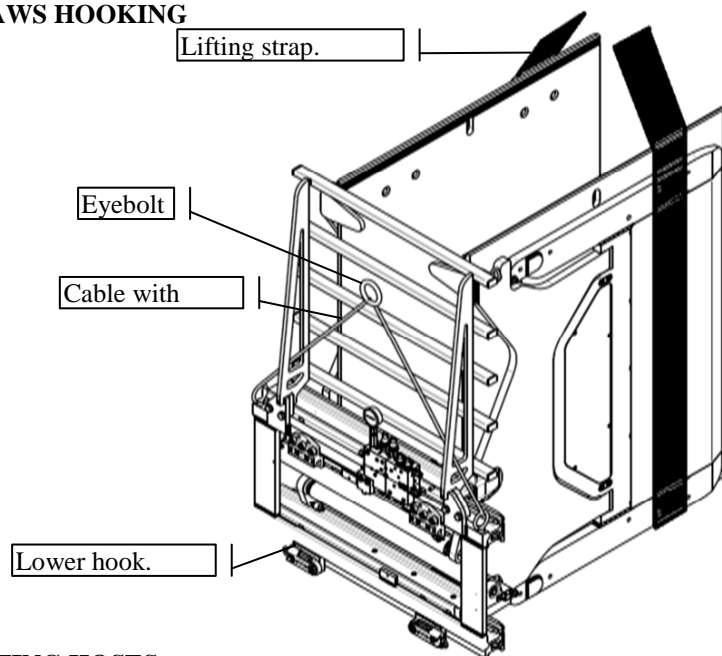

5.4. HOOK ADJUSTMENT

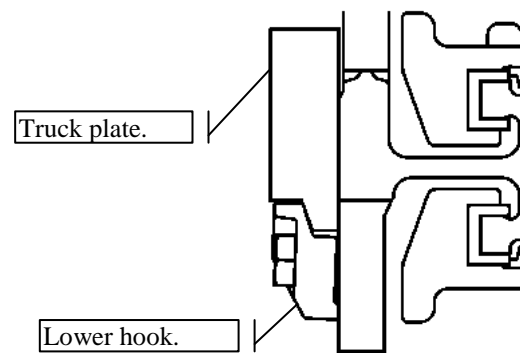

The lower hooks must lock the attachment to the fork-holder plate.

5.5. CONNECTING HOSES



YOU MUST APPLY A PROTECTION OR DEVICE TO THE JAW-OPEN CONTROL LEVEL TO AVOID ACCIDENTALLY PUSHING IT AND LOSING THE LOAD. THE MANUFACTURER OF THE TRUCK, OR THE INSTALLER, IS RESPONSIBLE FOR APPLYING THIS DEVICE.



Before connecting the hoses, eliminate the pressure in the truck's circuit following the manufacturer's instructions.



Oil can spill out of the hoses. Prepare a container to collect the fluid.



The connection hoses between valve and truck power plant are options.

5.5.1. WITHOUT SHIFTING

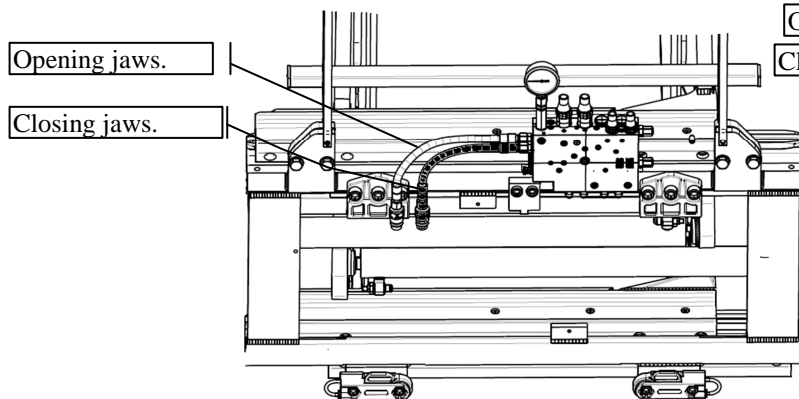

5.5.2. INCORPORATED SHIFTING

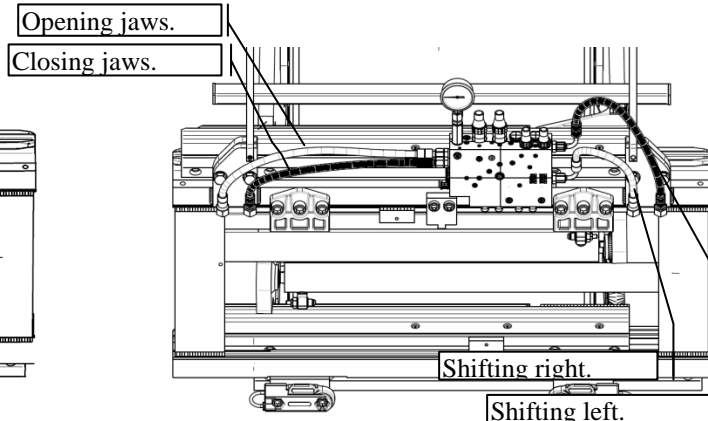

5.6 FITTING CONNECTION

- 1) Clamp the fixed fitting with a 17-mm ISO 3318
- 2) Tighten the fastening nut with a 19-mm ISO 3318

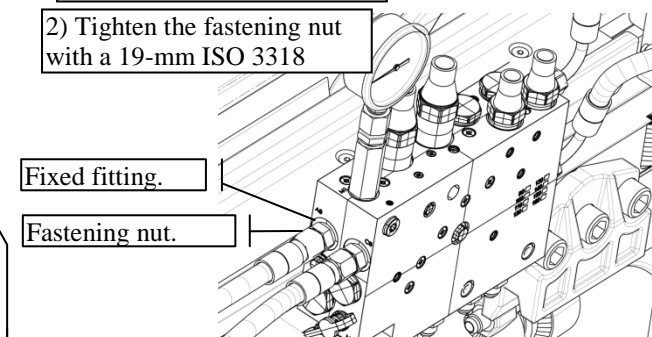

USE AND MAINTENANCE MANUAL

6. HYDRAULIC POWER PLANT CONNECTION AND DIAGRAM

6.1. MOVEMENT CHECK



YOU MUST APPLY A PROTECTION OR DEVICE TO THE JAW-OPEN CONTROL LEVEL TO AVOID ACCIDENTALLY PUSHING IT AND LOSING THE LOAD. THE MANUFACTURER OF THE TRUCK, OR THE INSTALLER, IS RESPONSIBLE FOR APPLYING THIS DEVICE.



Before connecting the hoses, eliminate the pressure in the truck's circuit following the manufacturer's instructions.



Oil can spill out of the hoses. Prepare a container to collect the fluid.



To check the connections, perform 5 complete movements without and with a

6.2. 1. WITHOUT SHIFTING

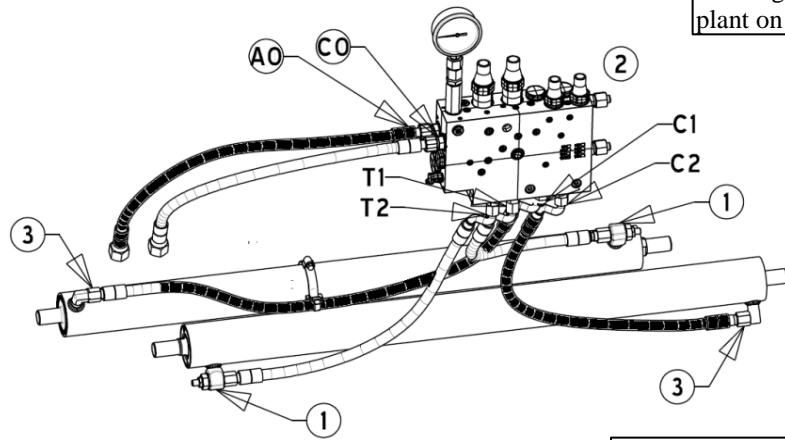

Existing power plant on the truck.

4th

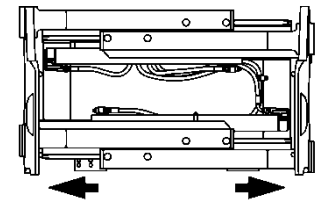
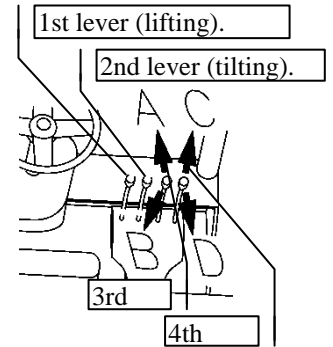
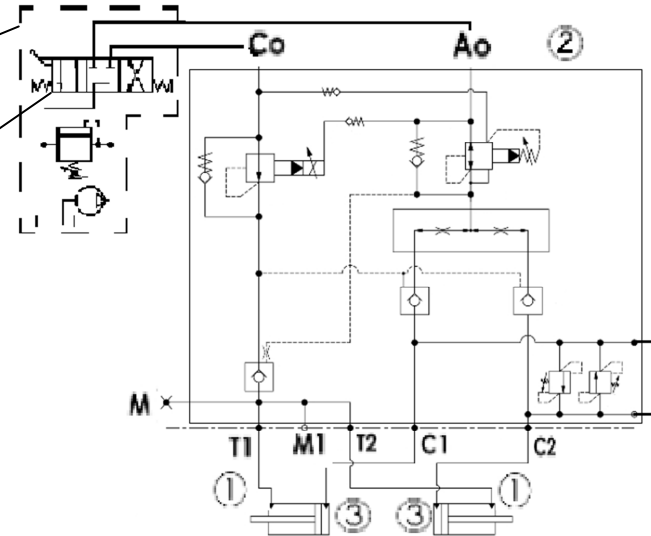

6.2.2. WITH SHIFTING INCORPORATED

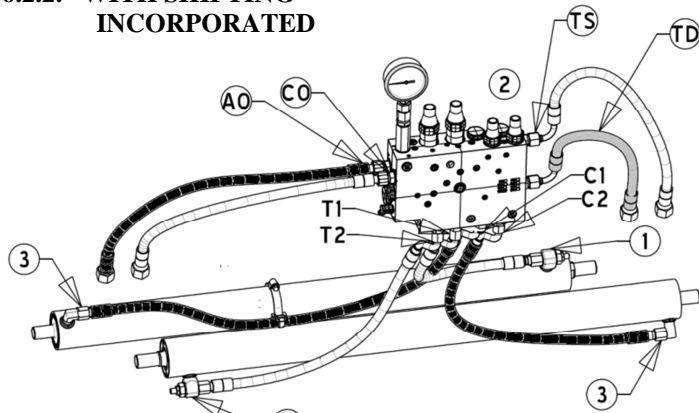

Existing power plant on the truck.

3rd

4th

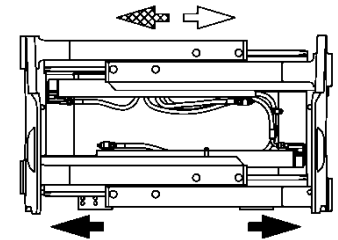
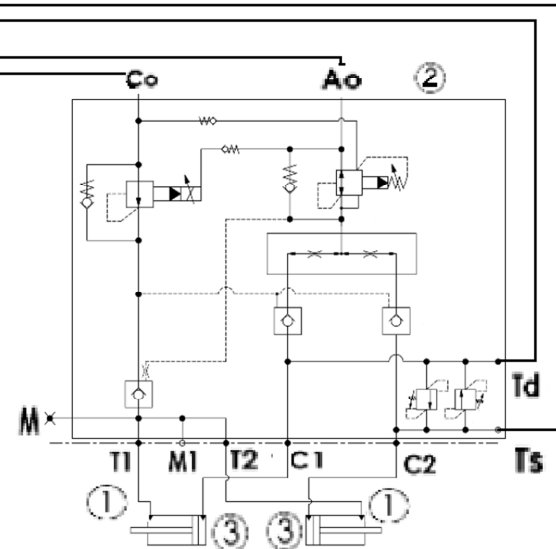

7. CHECKS AND ADJUSTMENTS

USE AND MAINTENANCE MANUAL

! The valves are preset and checked during final acceptance testing with in-house controllers. Perform the indicated checks/adjustments if there are anomalies, loss of load or lack of synchronism of the jaws.

! Before connecting the hoses, eliminate the pressure in the truck's circuit following the manufacturer's instructions.



Contact the post-sales support office before adjusting the tightening pressure.



With the application of the manometer, you only check/record the pressure in the hydraulic circuit for the gripping of the load

7.1. CLAMPING PRESSURE

Take the manometer reading with the attachment at its minimum opening.

The maximum pressure, which must not be exceeded, is indicated on

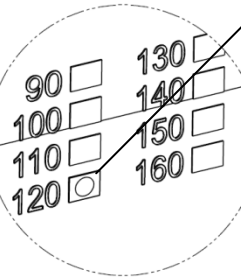
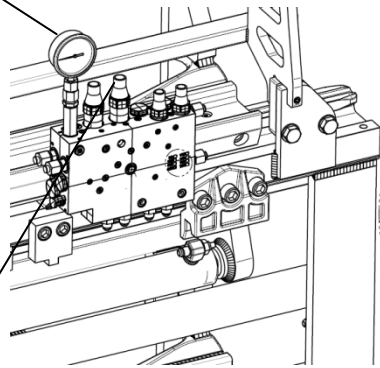

Remove the protection with a 24-mm ISO 3318 wrench; loosen the lock nut with a 17-mm ISO 3318 wrench; make the adjustment with a 5-mm ISO 3926 wrench, tightening to increase the pressure; tighten the lock nut.



The protection of the regulator valve is an anti-tampering safety feature. The manufacturer will not be liable for damage or breakage if not contacted before any adjustments.

7.2. SPEED AND SYNCHRONISM



To restore the synchronism, adjust the cylinder of the slow jaw to avoid a reduction of the total closing speed. A speed difference of 10% of the travel is allowed between the jaws.

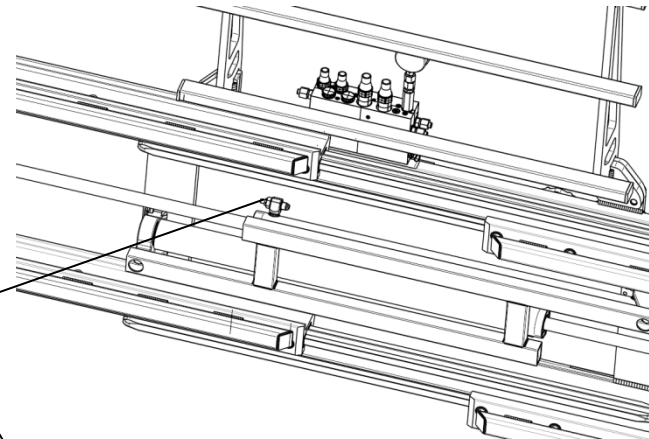

Loosen the lock nut with a 13-mm ISO 3318 wrench, open the screw by 90° with a 4-mm ISO 3926 wrench and check the results; repeat the adjustment until the desired result is obtained. At the end of adjustment, tighten the lock nut.

USE AND MAINTENANCE MANUAL

7.3 JAWS ADJUSTMENT

Jaws are adjusted and checked during the testing stage. Perform the indicated checks/adjustments if there are anomalies, loss of load.

! 7.3.1 ADJUSTING THE PANEL SUPPORTS CONVERGENCE

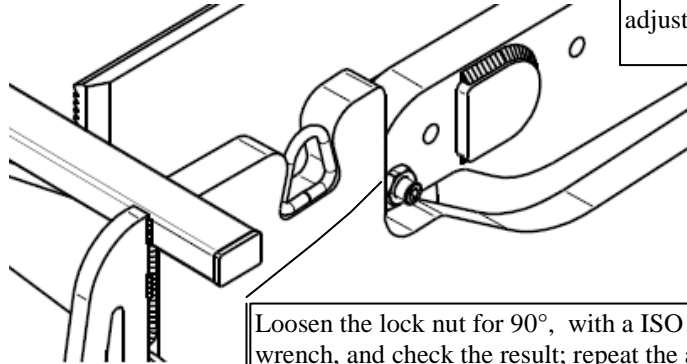

Loosen the lock nut for 90°, with a ISO 3926 - 8 mm wrench, and check the result; repeat the adjustment until the desired result is obtained. At the end of adjustment, tighten the lock nut.

The tilting of each panel can be adjusted by adding or removing shims in the given four positions. Fix the panel in its slot, loosen the panel locking screws with a ISO 3318 19 mm wrench, add 1 or 2 shims. After the adjustment, tighten the screws.

7.3.2 PANEL SUPPORTS TILTING ADJUSTMENT

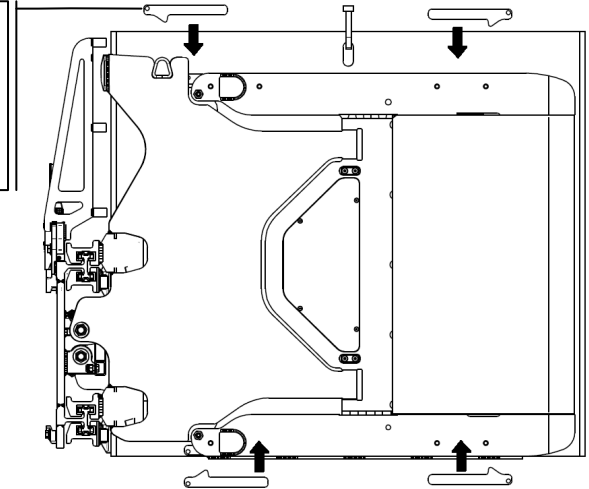

8. DAILY CHECKS

! At the start of every work shift, check the points to the side and inform maintenance personnel of any problems.

Check the tightness of the nuts fastening the rod and bottom of the fork movement cylinders.

The attachment's centre tooth must engage the centre notch of the truck's fork-holder plate.

Check for any leaks from the jaw movement cylinders.

Check that the lower jaws are correctly positioned and fastened.

Check the cleanliness and lubrication of the guides or slide block tracks.

Check the jaws joints and that the panel fixing screws are tight.

Check that the panel convergence adjusting grubs are properly set.

Check that the grid fixing screws are well tight.

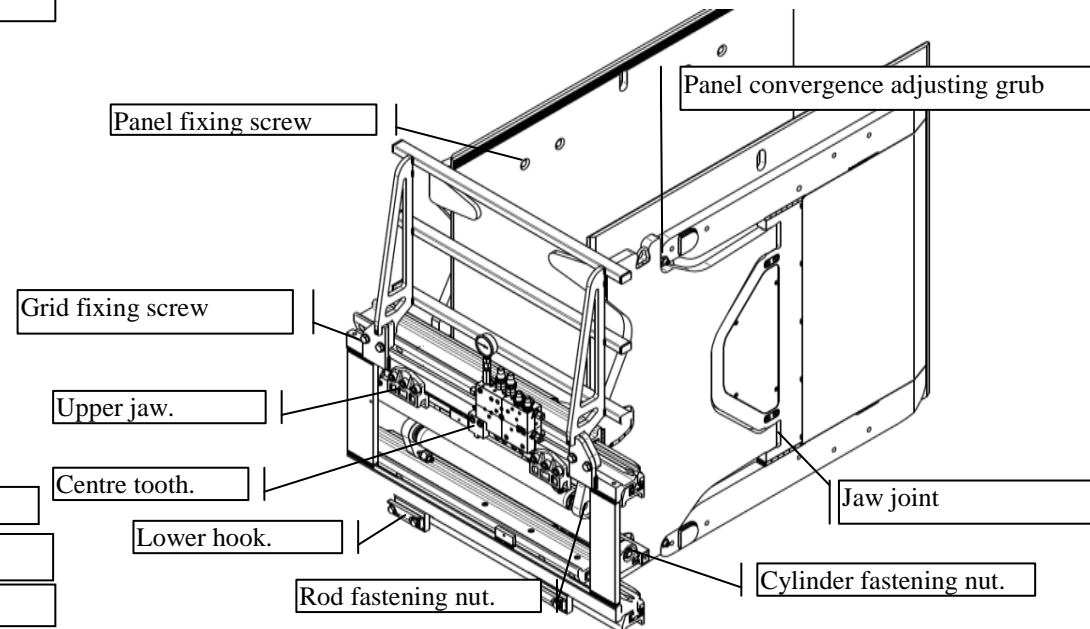

USE AND MAINTENANCE MANUAL

9. REGULAR MAINTENANCE

PERIODIC MAINTENANCE DIAGRAM		
OPERATIONS	Hours of work	
Clamp for appliances		
Clean and grease jaw-sliding "a" guides.	200	
Check screw tightness and oil leaks from the hydraulic connections.		
Check that the nameplates and safety stickers in "c" are easy to read.		
In addition to the operations for every 200 working hours, do the following:		
Check slide blocks "b" and replace if necessary.	1000	
Check the tightening pressure and synchronism of the jaws.		
Check the condition of the flexible hoses and fittings.		
Check hydraulic actuators "d"; check for oil leaks from the plug and the condition of the chromium plated rod surface.		
Check the wear on the clamping surface of the panels.		
Check the panel "g" support joint.	2000	
In addition to the operations for every 200 and 1000 working hours, do the following:		
In the area "f", check for wear on the parts sliding on the ground.		
Check the integrity of jaw-fastening base "e".	2000	
Look for deformations or breakage in the structure or welds.		

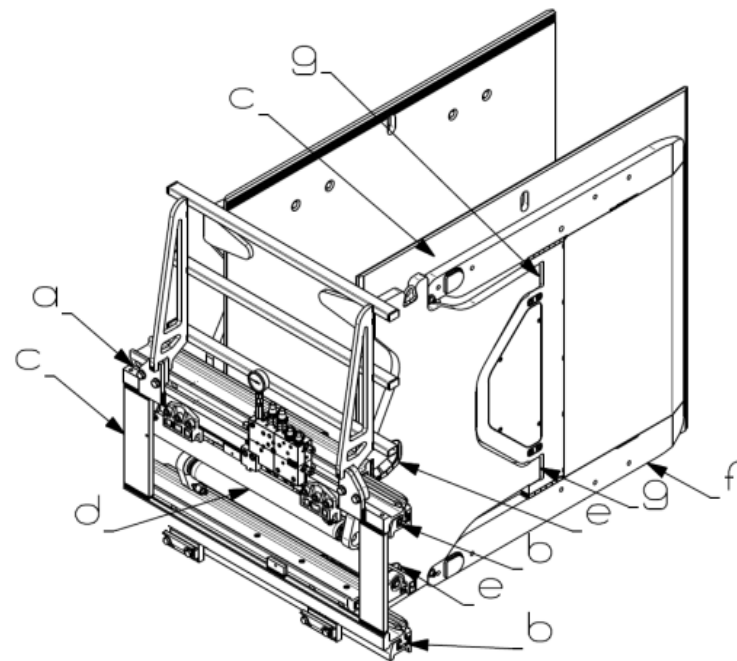

Before connecting-disconnecting the hoses, eliminate the pressure in the truck circuit following the manufacturer's



IF THE EQUIPMENT IS USED IN DUSTY, HUMID OR CORROSIVE ENVIRONMENTS, WE RECOMMEND HALVING THE HOURS OF WORK.



**Recommended Lubricants:
For insides: ISO X M2 (SHELL ALVANIA GREASE R2). Outsidess: ISO CB 32 (ESSO)**

USE AND MAINTENANCE MANUAL

ⓘ 10. EXTRAORDINARY MAINTENANCE

10.1. PANEL DISASSEMBLING

ⓘ Attachment fixed to the truck or positioned so that the panel can be removed.

1) Bring the jaws to their maximum

2) Remove the panel from its support by means of a torque wrench ISO 1174 - 19 mm, loosen the 8 screws after having attached the panel in its slot.

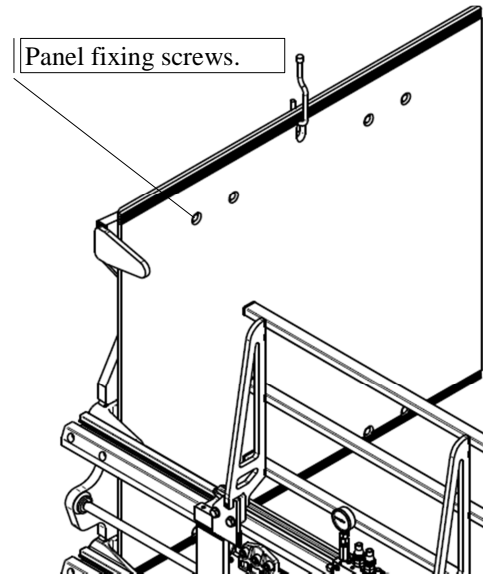

10.2 PANEL SUPPORT DISASSEMBLING

ⓘ Equipment fixed to the fork lift or positioned in such way to remove the panel support. To remove the support, the panel must be removed in advance.

1) Attach the support fixing a hook/eyebolt in its bores.

2) Remove the cover of the panel joining pins, by removing the screws with a ISO 3926 3 mm wrench.

3) Remove the pin fixing blocks, removing their screws with an ISO 3926 - 5 mm wrench. Remove the panel joining pins.

4) Now the panel support can be removed.

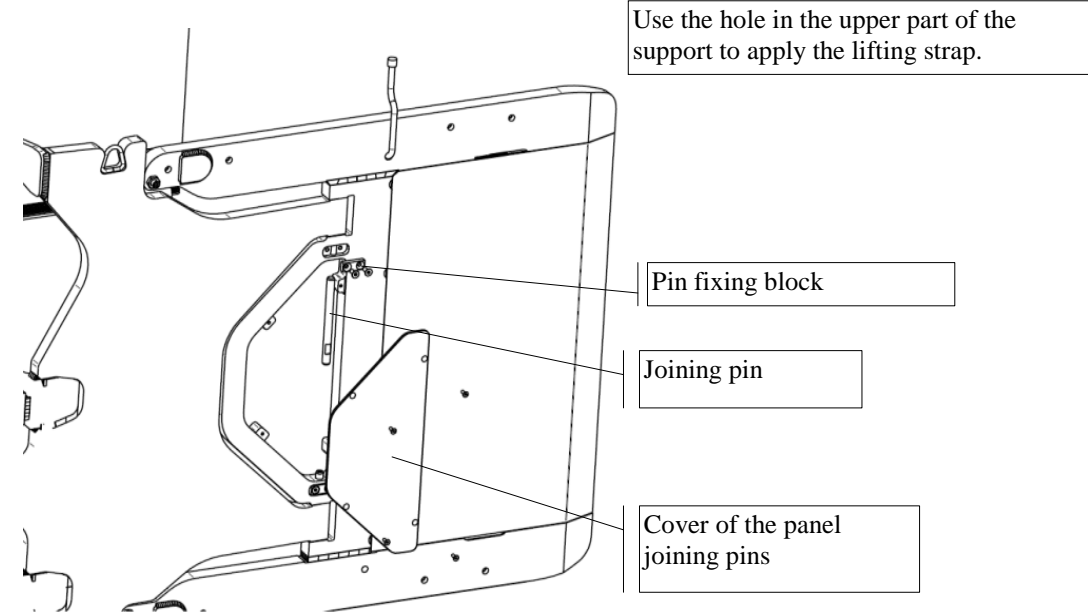

USE AND MAINTENANCE MANUAL

10.3. JAW DISASSEMBLING

⚠ Attachment fixed to the truck or positioned so that you can move the jaws hydraulically.

1) Bring the jaws to their maximum

2) Disconnect the jaw from the cylinder using a 22-mm ISO 3318 wrench to clamp the rod and a 30-mm ISO 1174 socket wrench to unscrew the

3) Bring the cylinders to their minimum closure, supporting the upper cylinder.

4) Take the jaw out by the side, and lay it on the ground.

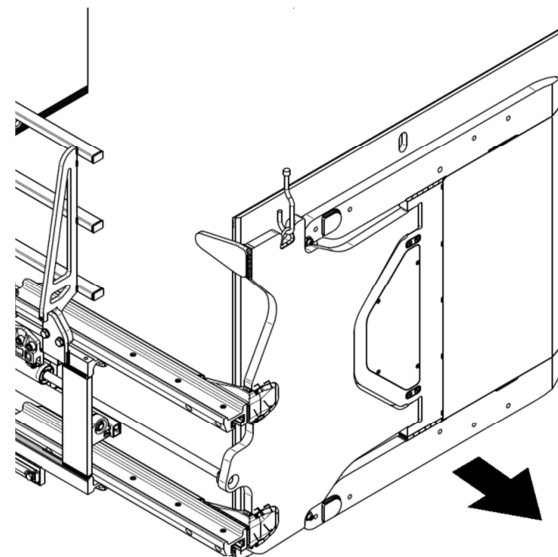

Use the slot in upper part of the jaw to attach the hook.



The balance of the jaw or fork becomes unstable when not guided by the frame.



TO PUT BACK THE DISASSEMBLED PARTS, PERFORM THE PROCEDURE DESCRIBED ABOVE IN REVERSE.

10.4. SLIDE BLOCK DISASSEMBLY

1) Remove the screws, with a ISO 3926 4 mm wrench and remove the slide block.

2) Using an 8-mm DIN 6450 punch, unlock the slide blocks and slide them off of the guide.

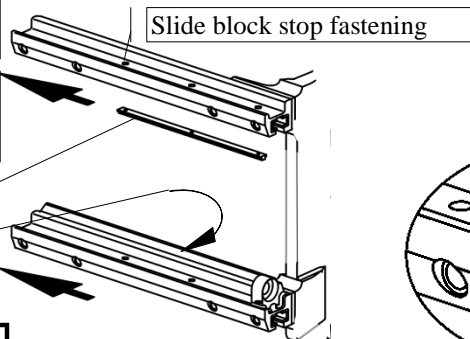

Slide block stop.

Front slide block

For the front slide blocks of the jaw use an ISO 2380 screwdriver because there are no release holes.



Position the stop correctly when mounting the new slide blocks.



TO PUT BACK THE DISASSEMBLED PARTS, PERFORM THE PROCEDURE DESCRIBED ABOVE IN REVERSE.

USE AND MAINTENANCE MANUAL

10.5. SLIDE BLOCK REPLACEMENT

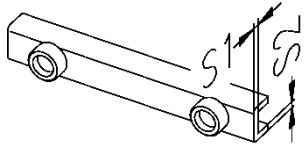

Replace the slides if broken, bent or if their thickness is lower than S1 4 mm; S2 5 mm.

10.6. CYLINDER ROD FASTENING

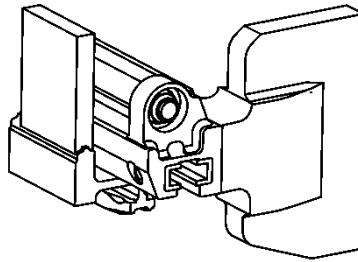

Tighten the nut until the Bellevue spring is locked and tighten 90°.

10.7. CYLINDER BOX FASTENING

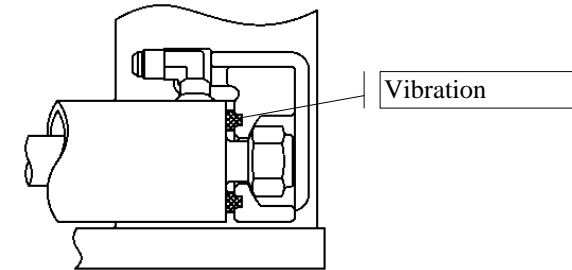

Check that the shock absorber is perfectly inserted in its seat and tighten until the cylinder is locked.

10.8. CYLINDER DISASSEMBLY

! Before connecting-disconnecting the hoses, eliminate the pressure in the truck circuit following the manufacturer's

! Oil can spill out of the hoses. Prepare a container to collect the fluid.

! Attachment fixed to the truck or positioned so that you can move the jaws hydraulically.

- 1) With the clamp at its minimum opening, position the jaw at an opening of 500 mm.
- 2) Remove the fixing screws of the cylinders protection shield by means of a bush wrench ISO 1174 19 mm, and remove shield.
- 3) Disconnect the cylinders from the jaws using a 22-mm ISO 3318 wrench to clamp the rod and a 30-mm ISO 1174 socket wrench to unscrew the nut.
- 4) Bring the cylinders to their minimum
- 5) Disconnect the flexible hoses from the cylinders with a 19-mm ISO 3318
- 6) Use a 30-mm socket wrench to unscrew the bottom-side nut and remove the cylinder.

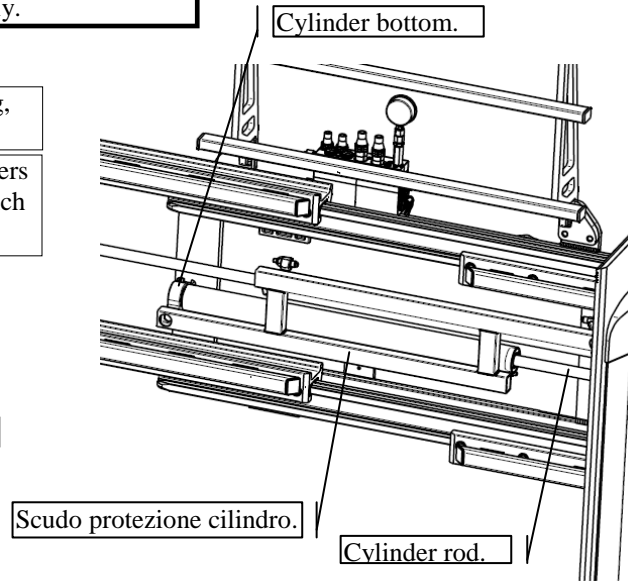

10.8.1. GASKET REPLACEMENT

- 1) To replace the "OR" gasket seal inside the regulator, use a 13-mm ISO 3318 wrench and 4-mm ISO3926 wrench.
- 2) Use a 19-mm ISO 3318 wrench to replace the copper seal washer.
- 3) Use a 12-60-mm spanner wrench and 4-mm-diameter pin to remove the cylinder plug.

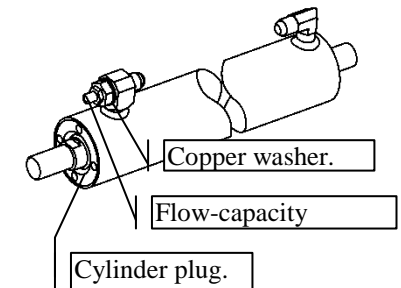

10.8.2. GASKET ASSEMBLY

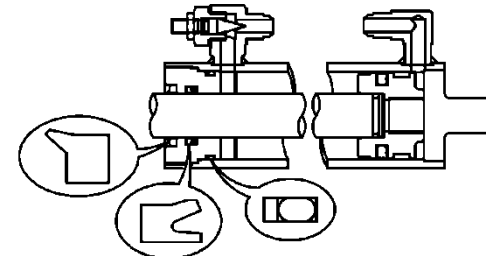

! When replacing the gaskets, taken care to match the mounting direction and work in an area protected from

USE AND MAINTENANCE MANUAL

10.9. VALVE DISASSEMBLY

! Oil can spill out of the hoses. Prepare a container to collect the fluid.

! You must disconnect the attachment from the truck to remove the

- 1) Dismount the lower hooks with an ISO 3318
- 2) Disconnect the flexible power hoses from the valve with a 19-mm ISO 3318
- 3) Fasten no. 2 eyebolts to the ends of the
- 4) Using UNI ISO 4479 hooks with cables, lift the attachment and rest it on the ground.
- 5) Disconnect the flexible hoses from the valve with a 19-mm ISO
- 6) Disconnect the valve block using a 6-mm ISO 3926

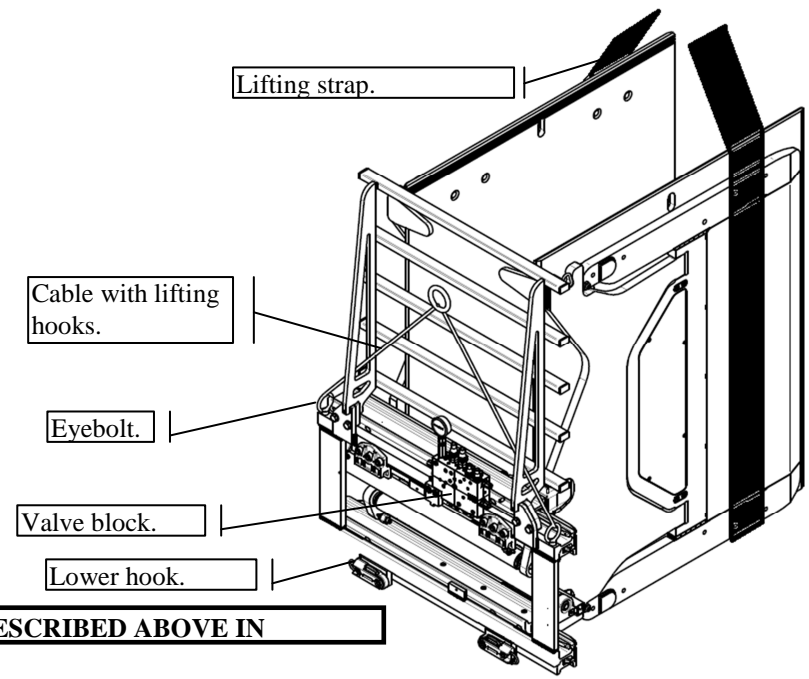

! TO PUT BACK THE DISASSEMBLED PARTS, PERFORM THE PROCEDURE DESCRIBED ABOVE IN

10.10. LOAD SUPPORTING GRID

- 1) Hook the grid by means of lifting cables.
- 2) Remove the load supporting grid fixing screws, by means of an ISO 3318 22 mm wrench
- 3) Now the grid can be removed and laid on the ground.

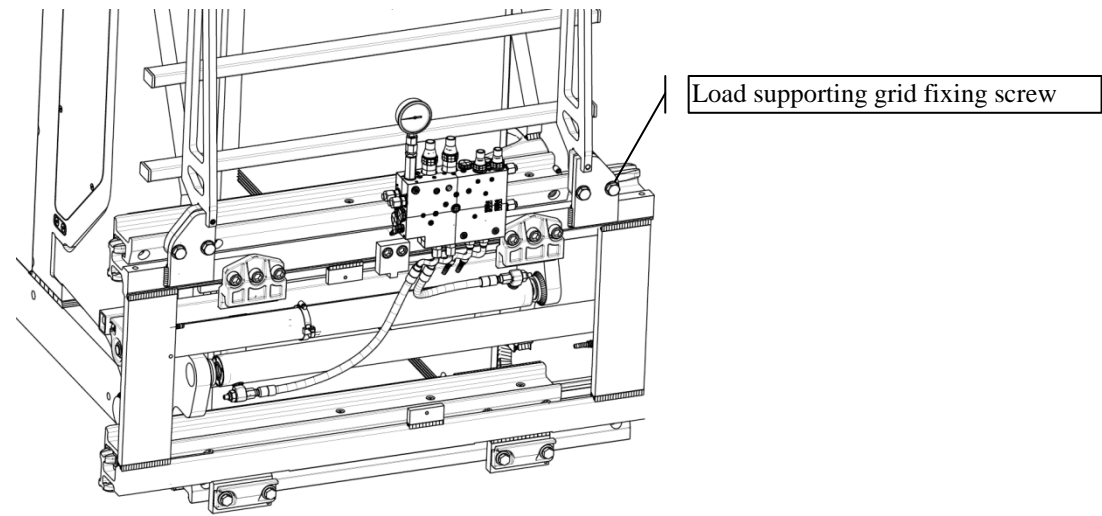

! TO PUT BACK THE DISASSEMBLED PARTS, PERFORM THE PROCEDURE DESCRIBED ABOVE IN

USE AND MAINTENANCE MANUAL

11. TROUBLESHOOTING

Clamping force insufficient with slipping or loss of load.	Insufficient oil pressure and/or flow.	Check and/or adjust the hydraulic pump and oil level in the tank of the truck. Check and adjust the attachment's valve.
	Residual air in the hydraulic circuit.	Check the oil level in the forklift's tank. Remove the residual air in the circuit.
	Hydraulic pump worn.	Replace the truck's hydraulic pump.
	Obstruction or leaks in the hydraulic circuit.	Check the hoses and connections of the hydraulic power plant of the truck-attachment; remove the obstructions or leaks, replacing damaged hoses.
	Oil oozing in cylinders or valve.	Replace the cylinder gaskets or replace the valve.
	Surface of the panel, in contact with the load, worn.	Restore the initial state of the surface or replace the panel.
	Incorrect jaws alignment/tilting.	Modify the jaws alignment/tilting, as given in "JAWS ADJUSTMENT".
Load damaged after clamping.	Pressure limiting valve with adjusted to excessive force.	Check and adjust valve.
	Pressure limiting valve malfunction.	Replace valve.
	Surface of the jaw, in contact with the load, worn.	Restore the initial state of the surface or replace the jaw.
	Incorrect jaws alignment/tilting.	Modify the jaws alignment/tilting, as given in "JAWS ADJUSTMENT".
The jaws close or open slowly or irregularly.	Insufficient oil pressure and/or flow.	Check and/or adjust the hydraulic pump and oil level in the tank of the truck. Check and adjust the attachment's valve.
	Residual air in the hydraulic circuit.	Check the oil level in the forklift's tank. Remove the residual air in the circuit.
	Hydraulic pump worn.	Replace the truck's hydraulic pump.
	Obstructions or breakage in the hydraulic circuit.	Remove the obstruction or replace the damaged hose.
	Oil oozing in cylinders or valve.	Replace the cylinder gaskets or replace the valve.
	Excessive friction between the sliding guides.	Clean and grease. Check the integrity of the guides and remove any deformations. Check and/or replace the slide blocks.
	Flow-capacity limiter of the cylinder closed too much. Regeneration circuit not adjusted.	Adjust as shown in the point "SPEED AND SYNCHRONISM"
Side shifting slow, irregular or blocked.	Insufficient oil pressure and/or flow.	Check and/or adjust the hydraulic pump and oil level in the tank of the truck. Check and adjust the attachment's valve.
	Residual air in the hydraulic circuit.	Check the oil level in the forklift's tank. Remove the residual air in the circuit.
	Hydraulic pump worn.	Replace the truck's hydraulic pump.
	Obstructions or breakage in the hydraulic circuit.	Remove the obstruction or replace the damaged hose.
	Oil oozing in cylinders or valve.	Replace the cylinder gaskets or replace the valve.
	Excessive friction between the sliding guides.	Check the slide blocks, the integrity of the guides, remove any deformations, clean and grease.
	Flow-capacity limiter of the cylinder closed too much.	Adjust as shown in the point "SPEED AND SYNCHRONISM"

IN CASE OF PROBLEMS NOT DESCRIBED ABOVE, CONTACT OUR SERVICE DEPARTMENT

USE AND MAINTENANCE MANUAL

12. NOISE

13. RECYCLING



THE SPECIFICATIONS THAT FOLLOW APPLY TO THE TRUCK-ATTACHMENT UNIT.

- Acoustic pressure level of the weighted emission A in the work place, if it exceeds 70 dB(A); if this level does not exceed 70 dB(A), it must be indicated.

-The maximum value of the instantaneous weighted acoustic pressure C in the work place, if it exceeds 63 Pa (130 dB with respect to 20 µPa).

-Weighted acoustic power level A emitted by the machine, if the weighted acoustic pressure level A in the work place exceeds 80 dB(A).

14. WARRANTY

The manufacturer warrants all its products for 12 months or 2000 working hours (whichever comes first) from the date of shipment.

If used for more than 8 hours per day, the warranty period will be reduced proportionally.

The guarantee is limited to the replacement, carriage forwards manufacturer plant of those parts the same manufacturer recognises to be defective owing to material or processing faults and does not include the labour cost or transfer cost for the replacement of such parts.

In addition, it is understood that the warranty is void if the problem is due to inappropriate use of the product, if it was not put into service following the manufacturer's instructions or if other than original replacement parts were used for modifications and/or repairs.

The attachment is not warranted for uses that exceed the capacities shown on the plate and in the documentation.

All attachments are covered by insurance against any damage to third parties caused by defective pieces or their incorrect functioning; any damage caused by incorrect or improper use is excluded.

Disposal of replaced parts must be carried out in the same way of a full scrapping, separating them according to the nature of their materials and complying with laws governing the disposal of solid industrial waste.

NOTE: Pieces not listed in the table to the side are steel.

Pallet for transport	Wood
Belts for fixing and protective covering for shipping	Polyester and heat-shrink
Cylinder plugs	Cast iron
Guide slide blocks	Nylon
Pipes/fittings	Polyester/steel
Gaskets	Polyurethane and NBR
Paint	Polyester epoxy
Gearmotor and grease	Dispose of in conformity with local law

15. FACSIMILE OF CERTIFICATE OF CONFORMITY

Dichiarazione CE di Conformità

Noi NOME COSTRUTTORE

INDIRIZZO COSTRUTTORE

XXXXXXXXXXXXXXXXXXXX

Dichiariamo sotto la nostra esclusiva responsabilità che il prodotto:

Tipo YYYYYYYYYYYYYYYYYY

Marca XXXXXXXXXXXXXXXXXX

Modello XXXXXXXXXXXX

Matricola JJJJJJJJJJ

Anno di fabbricazione VVVV

è conforme alle disposizioni della Direttiva Macchine 2006/42/CE e alle disposizioni della norma EN 1726-2

Persona autorizzata a costituire il fascicolo tecnico

Nome Pietro

Cognome Foroni

Posizione Direttore Ufficio Tecnico

Indirizzo 29027 Casoni di Podenzano - Piacenza (Italy)

Persona autorizzata a redigere la dichiarazione

Nome Claudio

Cognome Carnieletto

Posizione Direttore Assicurazione Qualità e Post Vendita



Piacenza, 10 dicembre 2009